

# EV20 Oil Sealed Pump



The EV rotary vane pumps are designed to be used in a wide range of industrial and scientific applications. They can be used individually or with mechanical booster pumps to increase both performance and ultimate vacuum. They can operate continuously from atmosphere to ultimate.

With reliability and ease of service in mind, the EV range of pumps are designed for the industrial and scientific markets. Edwards Applications Specialists have unrivalled knowledge and can advise on pump selection, configuration and operation to suit any customers' requirements. The EV range can be supplied individually or as part of pre-engineered combinations using Edwards EH mechanical boosters.

## Features & Benefits

- Continuous operation from atmosphere to ultimate vacuum
- High pumping speed at low pressure
- Gas ballast valve fitted as standard
- Low noise and vibration
- Air cooled

## Dimensions

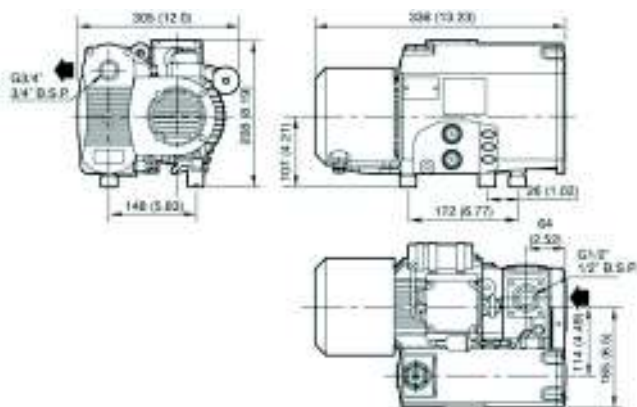

## Applications

- Furnaces and metallurgy industries
- Food processing and packaging
- Lifting
- Vacuum coating
- Vacuum transporting

## Performance Curves

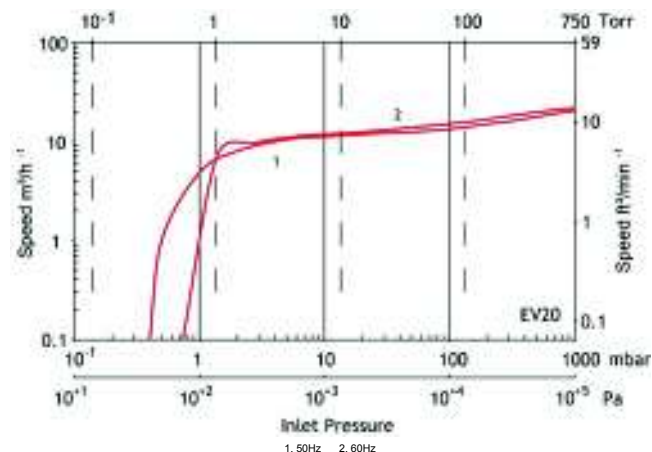

## Technical Data

Pumping speed 50 Hz	18 m <sup>3</sup> h <sup>-1</sup> / 11 ft <sup>3</sup> min <sup>-1</sup>
Pumping speed 60 Hz	21 m <sup>3</sup> h <sup>-1</sup> / 13 ft <sup>3</sup> min <sup>-1</sup>
Ultimate pressure without Gas Ballast	0.5 mbar
Water vapour capacity	0.4 kg h <sup>-1</sup> @ 10 mbar / 0.9 lb h <sup>-1</sup> @ 10 mbar
Electricity supply 50 Hz	175-260 / 300-450 V
Electricity supply 60 Hz	190-290 / 330-500 V
Motor Power 50 Hz	0.55 kW / 0.75hp
Motor Power 60 Hz	0.66 kW / 1.0 hp
Noise 50 Hz	63 dB(A)
Noise 60 Hz	67 dB(A)
Weight	20 kg / 44 lbs
Oil capacity	0.5 litre / 0.13 US gal
Oil Type	UG20

## Ordering Information

Product Description	Order No.
EV20 175-260/300-450V, 50Hz, 190-290/330-500V, 60Hz	A35010940

# EV40 Oil Sealed Pump

The EV rotary vane pumps are designed to be used in a wide range of industrial and scientific applications. They can be used individually or with mechanical booster pumps to increase both performance and ultimate vacuum. They can operate continuously from atmosphere to ultimate.

With reliability and ease of service in mind, the EV range of pumps are designed for the industrial and scientific markets. Edwards Applications Specialists have unrivalled knowledge and can advise on pump selection, configuration and operation to suit any customers' requirements. The EV range can be supplied individually or as part of pre-engineered combinations using Edwards EH mechanical boosters.



## Features & Benefits

- Continuous operation from atmosphere to ultimate vacuum
- High pumping speed at low pressure
- Gas ballast valve fitted as standard
- Low noise and vibration
- Air cooled

## Dimensions

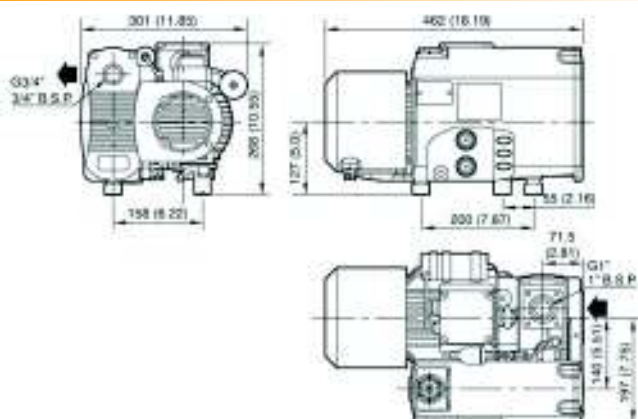

## Applications

- Furnaces and metallurgy industries
- Food processing and packaging
- Lifting
- Vacuum coating
- Vacuum transporting

## Performance Curves

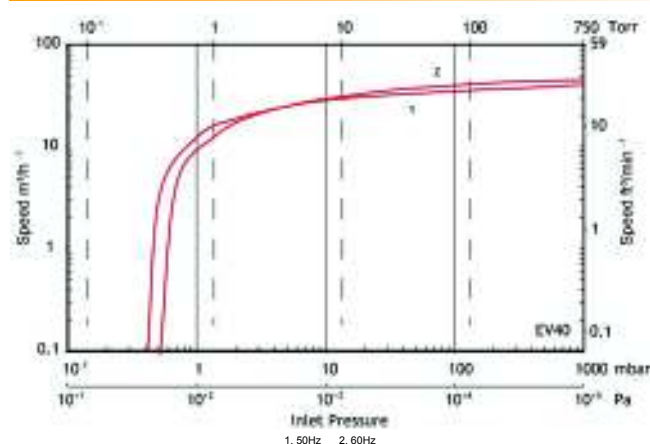

## Technical Data

Pumping speed 50 Hz	41 m <sup>3</sup> h <sup>-1</sup> / 25 ft <sup>3</sup> min <sup>-1</sup>
Pumping speed 60 Hz	48 m <sup>3</sup> h <sup>-1</sup> / 29 ft <sup>3</sup> min <sup>-1</sup>
Ultimate pressure without Gas Ballast	0.5 mbar
Water vapour capacity	0.3 kg h <sup>-1</sup> @ 10 mbar / 0.7 lb h <sup>-1</sup> @ 10 mbar
Electricity supply 50 Hz	190-255 / 330-440 V
Electricity supply 60 Hz	190-290 / 330-500 V
Motor Power 50 Hz	1.5 kW / 2.0 hp
Motor Power 60 Hz	1.8 kW / 2.5 hp
Noise 50 Hz	69 dB(A)
Noise 60 Hz	71 dB(A)
Weight	38 kg / 84 lbs
Oil capacity	1 litre / 0.26 US gal
Oil Type	UG20

## Ordering Information

Product Description	Order No.
EV40 190-255/330-440V, 50Hz, 190-290/330-500V, 60Hz	A35015940

# EV70 Oil Sealed Pump



The EV rotary vane pumps are designed to be used in a wide range of industrial and scientific applications. They can be used individually or with mechanical booster pumps to increase both performance and ultimate vacuum. They can operate continuously from atmosphere to ultimate.

With reliability and ease of service in mind, the EV range of pumps are designed for the industrial and scientific markets. Edwards Applications Specialists have unrivalled knowledge and can advise on pump selection, configuration and operation to suit any customers' requirements. The EV range can be supplied individually or as part of pre-engineered combinations using Edwards EH mechanical boosters.

## Features & Benefits

- Continuous operation from atmosphere to ultimate vacuum
- High pumping speed at low pressure
- Gas ballast valve fitted as standard
- Low noise and vibration
- Air cooled

## Dimensions

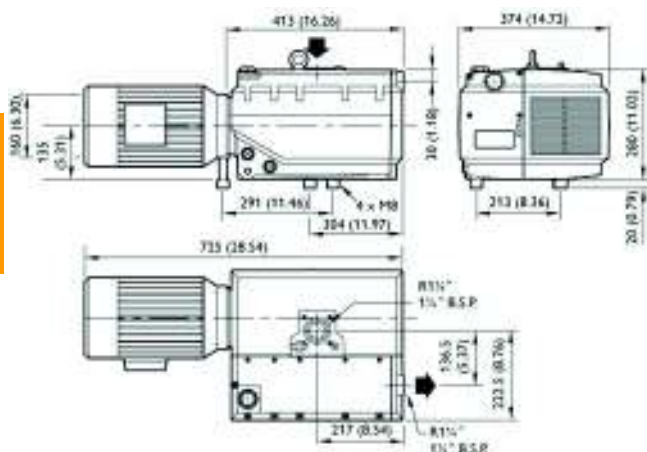

## Applications

- Furnaces and metallurgy industries
- Food processing and packaging
- Lifting
- Vacuum coating
- Vacuum transporting

## Performance Curves

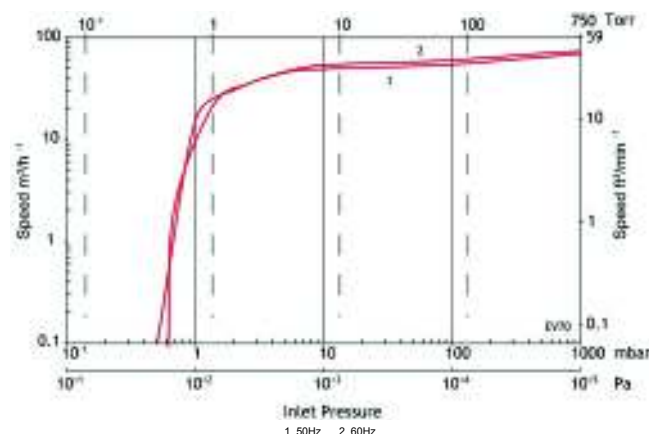

## Technical Data

Pumping speed 50 Hz	58 m <sup>3</sup> h <sup>-1</sup> / 35 ft <sup>3</sup> min <sup>-1</sup>
Pumping speed 60 Hz	73 m <sup>3</sup> h <sup>-1</sup> / 44 ft <sup>3</sup> min <sup>-1</sup>
Ultimate pressure without gas ballast	0.5 mbar
Water vapour capacity	0.57 kg h <sup>-1</sup> @ 10 mbar / 1.3 lb h <sup>-1</sup> @ 10 mbar
Electricity supply 50 Hz	190-255 / 330-440 V
Electricity supply 60 Hz	190-290 / 330-500 V
Motor Power 50 Hz	2.4 kW / 3.25hp
Motor Power 60 Hz	3 kW / 4.0hp
Noise 50 Hz	67 dB(A)
Noise 60 Hz	68.5 dB(A)
Weight	62 kg / 136 lbs
Oil capacity	2 litre / 0.53 US gal
Oil Type	UG20

## Ordering Information

Product Description	Order No.
EV70 190-255/330-440V, 50Hz, 190-290/330-500V, 60Hz	A35020940

# EV100 Oil Sealed Pump

The EV rotary vane pumps are designed to be used in a wide range of industrial and scientific applications. They can be used individually or with mechanical booster pumps to increase both performance and ultimate vacuum. They can operate continuously from atmosphere to ultimate.

With reliability and ease of service in mind, the EV range of pumps are designed for the industrial and scientific markets. Edwards Applications Specialists have unrivalled knowledge and can advise on pump selection, configuration and operation to suit any customers' requirements. The EV range can be supplied individually or as part of pre-engineered combinations using either Edwards EH mechanical boosters.



## Features & Benefits

- Continuous operation from atmosphere to ultimate vacuum
- High pumping speed at low pressure
- Gas ballast valve fitted as standard
- Low noise and vibration
- Air cooled

## Dimensions

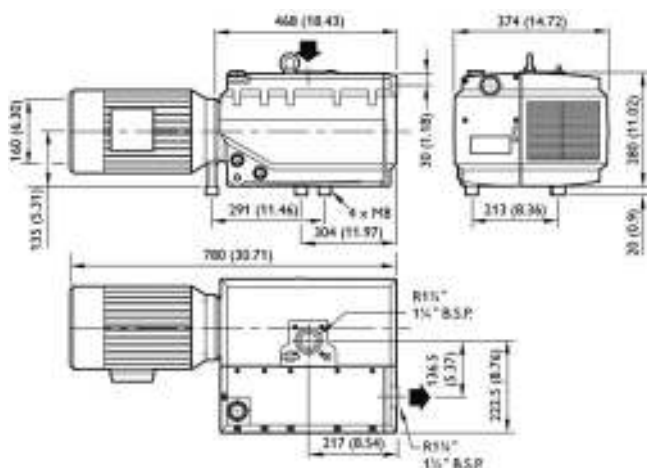

## Applications

- Furnaces and metallurgy industries
- Food processing and packaging
- Lifting
- Vacuum coating
- Vacuum transporting

## Performance Curves

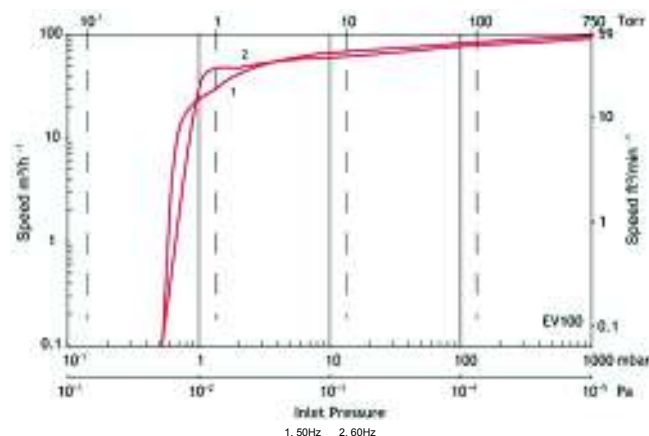

## Technical Data

Pumping speed 50 Hz	100 m <sup>3</sup> h <sup>-1</sup> / 60 ft <sup>3</sup> min <sup>-1</sup>
Pumping speed 60 Hz	117 m <sup>3</sup> h <sup>-1</sup> / 70 ft <sup>3</sup> min <sup>-1</sup>
Ultimate pressure without gas ballast	0.5 mbar
Water vapor capacity	0.36 kg h <sup>-1</sup> @ 10 mbar / 0.8 lb h <sup>-1</sup> @ 10 mbar
Electricity supply 50 Hz	190-255 / 330-440 V
Electricity supply 60 Hz	190-290 / 330-500 V
Motor Power 50 Hz	2.4 kW / 3.25 hp
Motor Power 60 Hz	3 kW / 4.0 hp
Noise 50 Hz	67.5 dB(A)
Noise 60 Hz	69 dB(A)
Weight	65 kg / 143 lbs
Oil capacity	2 litre / 0.53 US gal
Oil Type	UG20

## Ordering Information

Product Description	Order No.
EV100 190-255/330-440V, 50Hz, 190-290/330-500V, 60Hz	A35025940

# EV160 Oil Sealed Pump



The EV rotary vane pumps are designed to be used in a wide range of industrial and scientific applications. They can be used individually or with mechanical booster pumps to increase both performance and ultimate vacuum. They can operate continuously from atmosphere to ultimate.

With reliability and ease of service in mind, the EV range of pumps are designed for the industrial and scientific markets. Edwards Applications Specialists have unrivalled knowledge and can advise on pump selection, configuration and operation to suit any customers' requirements. The EV range can be supplied individually or as part of pre-engineered combinations using Edwards EH mechanical boosters.

## Features & Benefits

- Continuous operation from atmosphere to ultimate vacuum
- High pumping speed at low pressure
- Gas ballast valve fitted as standard
- Low noise and vibration
- Air cooled

## Dimensions

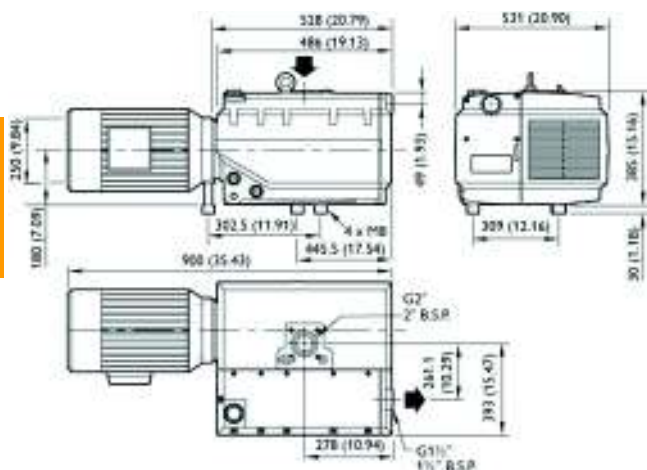

## Applications

- Furnaces and metallurgy industries
- Food processing and packaging
- Lifting
- Vacuum coating
- Vacuum transporting

## Performance Curves

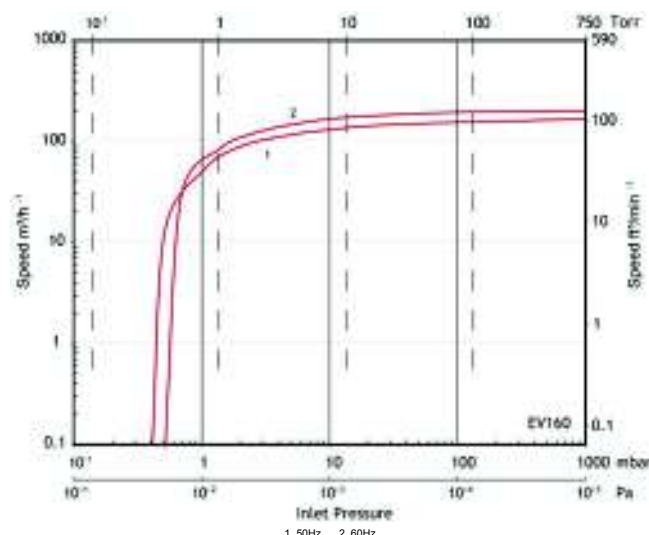

## Technical Data

Pumping speed 50 Hz	160 m <sup>3</sup> h <sup>-1</sup> / 96 ft <sup>3</sup> min <sup>-1</sup>
Pumping speed 60 Hz	192 m <sup>3</sup> h <sup>-1</sup> / 116 ft <sup>3</sup> min <sup>-1</sup>
Ultimate pressure without gas ballast	0.5 mbar
Water vapour capacity	1.2 kg h <sup>-1</sup> @ 10 mbar / 2.6 lb h <sup>-1</sup> @ 10 mbar
Electricity supply 50 Hz	190-255 / 330-440 V
Electricity supply 60 Hz	190-290 / 330-500 V
Motor Power 50 Hz	4 kW / 5.5 hp
Motor Power 60 Hz	4.8 kW / 6.5 hp
Noise 50 Hz	71 dB(A)
Noise 60 Hz	74 dB(A)
Weight	129 kg / 284 lbs
Oil capacity	7 litre / 1.84 US gal
Oil Type	UG20

## Ordering Information

Product Description	Order No.
EV160 190-255/330-440V, 50Hz, 190-290/330-500V, 60Hz	A35030940

# EV200 Rotary vane pump

The EV rotary vane pumps are designed to be used in a wide range of industrial and scientific applications. They can be used individually or with mechanical booster pumps to increase both performance and ultimate vacuum. They can operate continuously from atmosphere to ultimate.

With reliability and ease of service in mind, the EV range of pumps are designed for the industrial and scientific markets. Edwards Applications Specialists have unrivalled knowledge and can advise on pump selection, configuration and operation to suit any customers' requirements. The EV range can be supplied individually or as part of pre-engineered combinations using Edwards EH mechanical boosters.



## Features & Benefits

- Continuous operation from atmosphere to ultimate vacuum
- High pumping speed at low pressure
- Gas ballast valve fitted as standard
- Low noise and vibration
- Air cooled

## Dimensions

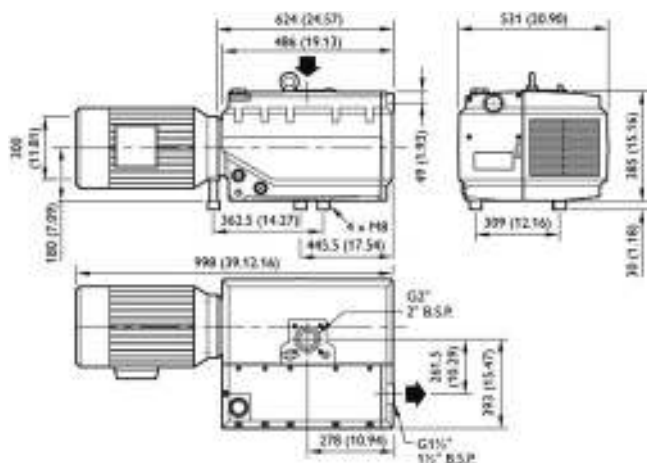

## Applications

- Furnaces and metallurgy industries
- Food processing and packaging
- Lifting
- Vacuum coating
- Vacuum transporting

## Performance Curves

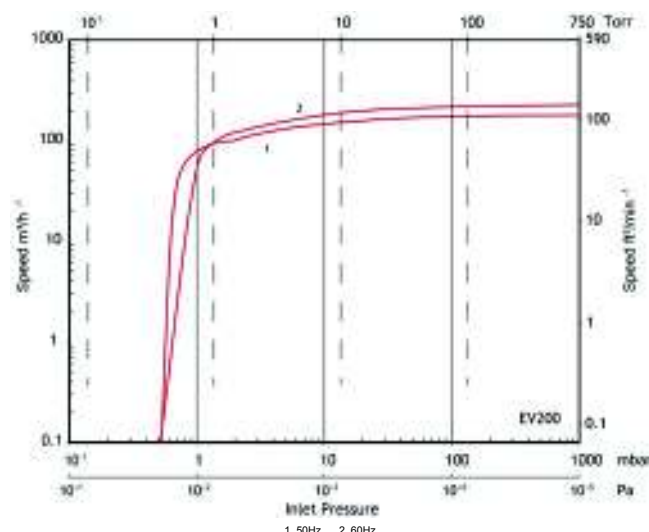

## Technical Data

Pumping speed 50 Hz	184 m <sup>3</sup> h <sup>-1</sup> / 111 ft <sup>3</sup> min <sup>-1</sup>
Pumping speed 60 Hz	221 m <sup>3</sup> h <sup>-1</sup> / 133 ft <sup>3</sup> min <sup>-1</sup>
Ultimate pressure without gas ballast	0.5 mbar
Water vapour capacity	1.33 kg h <sup>-1</sup> @ 10 mbar / 2.9 lb h <sup>-1</sup> @ 10 mbar
Electricity supply 50 Hz	340-430V / 588-745V or 200V
Electricity supply 60 Hz	340-500V / 590-865V or 200V
Motor Power 50 Hz	5.5 kW / 7.5 hp
Motor Power 60 Hz	6.4 kW / 8.5 hp
Noise 50 Hz	73 dB(A)
Noise 60 Hz	76 dB(A)
Weight	163 kg / 359 lbs
Oil capacity	7 litre / 1.84 US gal
Oil Type	UG20

## Ordering Information

Product Description	Order No.
EV200 200V, 50/60Hz	A35035934
EV200 340-430/588-745V, 50Hz, 340-500/590-865V, 60Hz	A35035940

# EV300 Rotary vane pump



The EV rotary vane pumps are designed to be used in a wide range of industrial and scientific applications. They can be used individually or with mechanical booster pumps to increase both performance and ultimate vacuum. They can operate continuously from atmosphere to ultimate.

With reliability and ease of service in mind, the EV range of pumps are designed for the industrial and scientific markets. Edwards Applications Specialists have unrivalled knowledge and can advise on pump selection, configuration and operation to suit any customers' requirements. The EV range can be supplied individually or as part of pre-engineered combinations using Edwards EH mechanical boosters.

## Features & Benefits

- Continuous operation from atmosphere to ultimate vacuum
- High pumping speed at low pressure
- Gas ballast valve fitted as standard
- Low noise and vibration
- Air cooled

## Dimensions

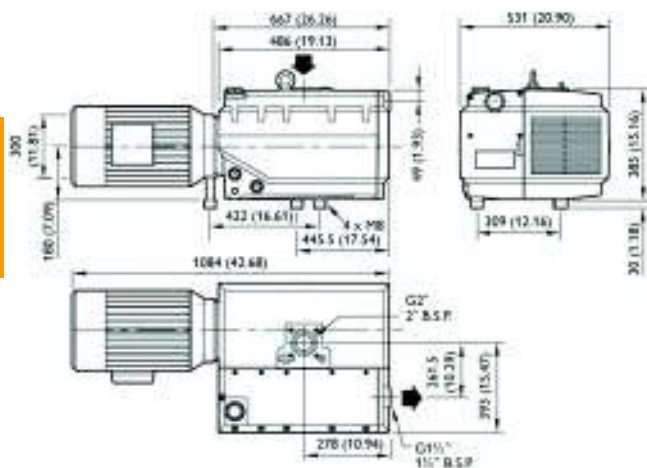

## Applications

- Furnaces and metallurgy industries
- Food processing and packaging
- Lifting
- Vacuum coating
- Vacuum transporting

## Performance Curves

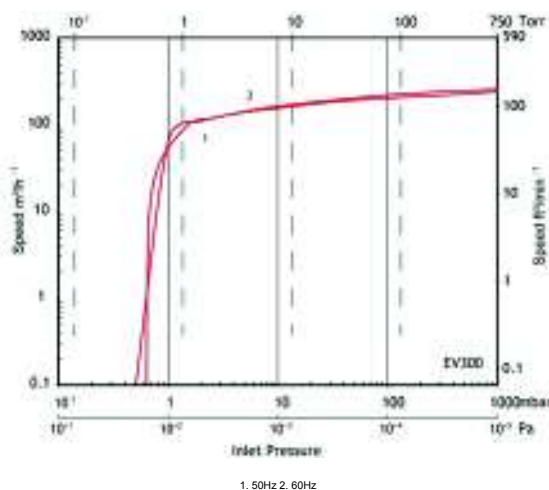

1. 50Hz 2. 60Hz

## Technical Data

Pumping speed 50 Hz	240 m <sup>3</sup> h <sup>-1</sup> / 145 ft <sup>3</sup> min <sup>-1</sup>
Pumping speed 60 Hz	274 m <sup>3</sup> h <sup>-1</sup> / 165 ft <sup>3</sup> min <sup>-1</sup>
Ultimate pressure without gas ballast	0.5 mbar
Water vapour capacity	1.4 kg h <sup>-1</sup> @ 10 mbar / 3.1 lb h <sup>-1</sup> @ 10 mbar
Electricity supply 50 Hz	340-430V / 588-745V or 200V
Electricity supply 60 Hz	340-500V / 590-865V or 200V
Motor Power 50 Hz	7.8 kW / 10.5 hp
Motor Power 60 Hz	9.3 kW / 12.5 hp
Noise 50 Hz	73 dB(A)
Noise 60 Hz	76 dB(A)
Weight	178 kg / 392 lbs
Oil capacity	7 litre / 1.84 US gal
Oil Type	UG20

## Ordering Information

Product Description	Order No.
EV300 200V, 50/60Hz	A35040934
EV300 340-430/588-745V, 50Hz, 340-500/590-865V, 60Hz	A35040940

# EV400 Rotary vane pump

The EV rotary vane pumps are designed to be used in a wide range of industrial and scientific applications. They can be used individually or with mechanical booster pumps to increase both performance and ultimate vacuum. They can operate continuously from atmosphere to ultimate.

With reliability and ease of service in mind, the EV range of pumps are designed for the industrial and scientific markets. Edwards Applications Specialists have unrivalled knowledge and can advise on pump selection, configuration and operation to suit any customers' requirements. The EV range can be supplied individually or as part of pre-engineered combinations using Edwards EH mechanical boosters.



## Features & Benefits

- Continuous operation from atmosphere to ultimate vacuum
- High pumping speed at low pressure
- Gas ballast valve fitted as standard
- Low noise and vibration
- Air cooled

## Dimensions

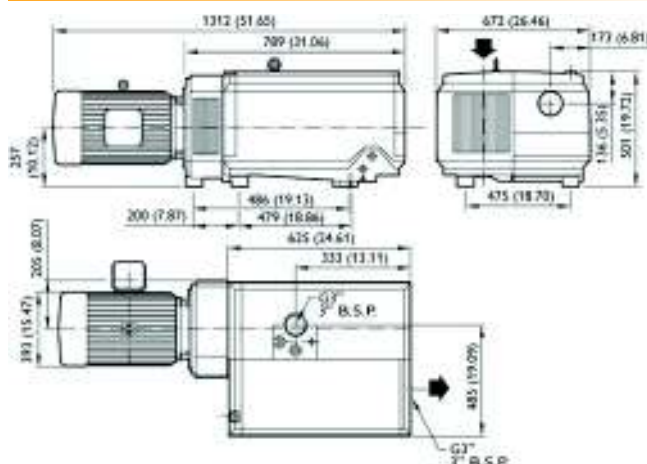

## Applications

- Furnaces and metallurgy industries
- Food processing and packaging
- Lifting
- Vacuum coating
- Vacuum transporting

## Performance Curves

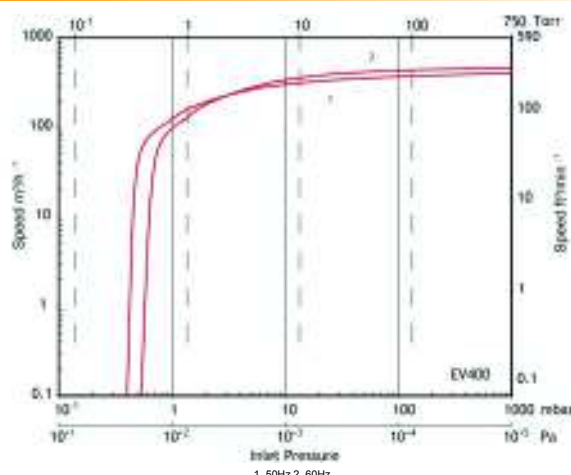

## Technical Data

Pumping speed 50 Hz	400 m <sup>3</sup> h <sup>-1</sup> / 241 ft <sup>3</sup> min <sup>-1</sup>
Pumping speed 60 Hz	480 m <sup>3</sup> h <sup>-1</sup> / 289 ft <sup>3</sup> min <sup>-1</sup>
Ultimate pressure without gas ballast	0.5 mbar
Water vapour capacity	6.0 kg h <sup>-1</sup> @ 10 mbar / 13.2 lb h <sup>-1</sup> @ 10 mbar
Electricity supply 50 Hz	340-430V / 588-745V or 200V
Electricity supply 60 Hz	340-500V / 590-865V or 200V
Motor Power 50 Hz	11 kW / 15 hp
Motor Power 60 Hz	12.5 kW / 17 hp
Noise 50 Hz	78 dB(A)
Noise 60 Hz	81 dB(A)
Weight	400 kg / 880 lbs
Oil capacity	15 litre / 3.96 US gal
Oil Type	UG20

## Ordering Information

Product Description	Order No.
EV400 200V, 50/60Hz	A35045934
EV400 340-430/588-745V, 50Hz, 340-500/590-865V, 60Hz	A35045940



# EV630 Rotary vane pump



The EV rotary vane pumps are designed to be used in a wide range of industrial and scientific applications. They can be used individually or with mechanical booster pumps to increase both performance and ultimate vacuum. They can operate continuously from atmosphere to ultimate.

With reliability and ease of service in mind, the EV range of pumps are designed for the industrial and scientific markets. Edwards Applications Specialists have unrivalled knowledge and can advise on pump selection, configuration and operation to suit any customers' requirements. The EV range can be supplied individually or as part of pre-engineered combinations using Edwards EH mechanical boosters.

## Features & Benefits

- Continuous operation from atmosphere to ultimate vacuum
- High pumping speed at low pressure
- Gas ballast valve fitted as standard
- Low noise and vibration
- Air cooled

## Dimensions

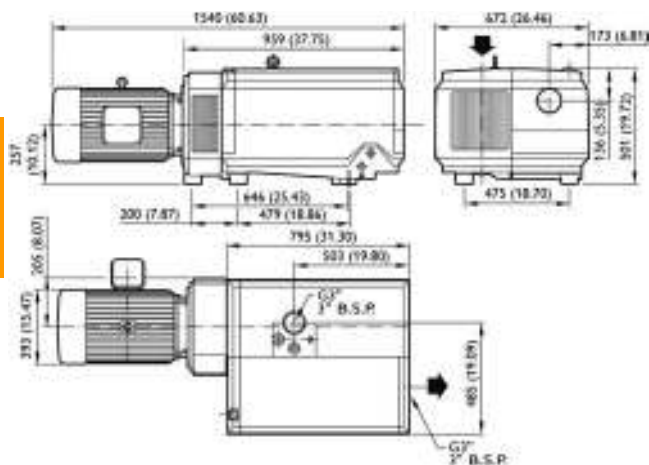

## Applications

- Furnaces and metallurgy industries
- Food processing and packaging
- Lifting
- Vacuum coating
- Vacuum transporting

## Performance Curves

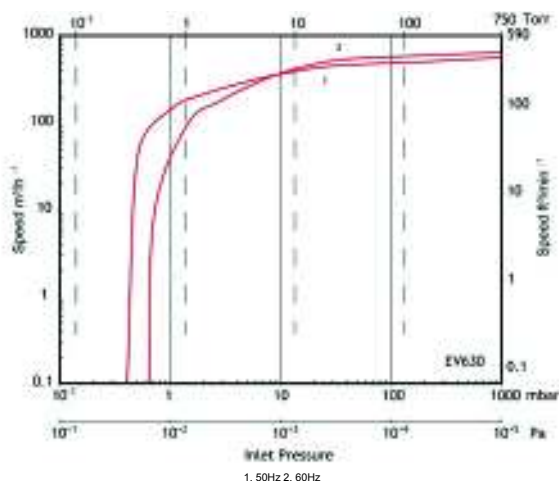

## Technical Data

Pumping speed 50 Hz	630 m <sup>3</sup> h <sup>-1</sup> / 380 ft <sup>3</sup> min <sup>-1</sup>
Pumping speed 60 Hz	750 m <sup>3</sup> h <sup>-1</sup> / 452 ft <sup>3</sup> min <sup>-1</sup>
Ultimate pressure without gas ballast	0.5 mbar
Water vapour capacity	10.4 kg h <sup>-1</sup> @ 4 mbar / 22.9 lb h <sup>-1</sup> @ 4 mbar
Electricity supply 50 Hz	400V / 690V* or 200V
Electricity supply 60 Hz	400V / 690V* or 200V
Motor Power 50 Hz	15 kW / 20 hp
Motor Power 60 Hz	18.5 kW / 25 hp
Noise 50 Hz	80 dB(A)
Noise 60 Hz	83 dB(A)
Weight	525 kg / 1155 lbs
Oil capacity	15 litre / 3.96 US gal
Oil Type	UG20

## Ordering Information

Product Description	Order No.
EV630 200V, 50/60Hz	A35050934
EV630 400/690V, 50/60Hz	A35050940

# Accessories for Single Stage Oil Sealed Pumps

## Oil Level Switch

An oil level switch is available to order as a separate item that can be fitted to give an indication or warning of low oil level in the pump. This allows the user to remotely monitor the oil level and add oil or plan maintenance to prevent potentially serious damage occurring to the pump.

### Ordering Information

Product Description	Order No.
Oil level switch EV20, EV40	A35010300
Oil level switch EV70, EV100, EV160, EV200, EV300, EV400, EV630	A35020300

## Inlet Filter

A full range of inlet filters for all models are available for use when there is the possibility of harmful dust or debris entering the pump during operation and potentially causing damage or increased wear to the pump mechanism.

### Ordering Information

Product Description	Order No.
Inlet filters complete with fittings	
Inlet filter EV20	A35010310
Inlet filter EV40	A35015310
Inlet filter EV70, EV100	A35025310
Inlet filter EV160, EV200, EV300	A35030310
Inlet filter EV400, EV630	A35045310
<b>Spares</b>	<b>Order No.</b>
Inlet filter element EV20	A35010700
Inlet filter element EV40	A35015700
Inlet filter element EV70, EV100	A35025700
Inlet filter element EV160, EV200, EV300	A35030700
Inlet filter element EV400, EV630	A35045700

## Spares

Three levels of spares kits are available. Filter kit containing exhaust mist filters, Service kit containing filter kit, seals and blades and an Overhaul kit containing service kit and parts to completely rebuild a pump such as bearings, etc.

### Ordering Information

Spares	Order No.
Filter kit EV20 (index A-B)	A35010800
Service kit EV20 (index A)	A35010810
Service kit EV20 (index B)	A35010811
Overhaul kit EV20 (index A)	A35010820
Overhaul kit EV20 (index B)	A35010821
Filter kit EV40	A35015800
Service kit EV40	A35015810
Service kit EV40 (index A)	A35015811
Overhaul kit EV40	A35015820
Overhaul kit EV40 (index A)	A35015821
Filter kit EV70 (index D-G)	A35020801
Service kit EV70 (index D-F)	A35020811
Service kit EV70 (index G)	A35020812
Overhaul kit EV70 (index F)	A35020822
Overhaul kit EV70 (index G)	A35020823
Filter kit EV100 (index D-G)	A35025801
Service kit EV100 (index D-F)	A35025811
Service kit EV100 (index G)	A35025812
Overhaul kit EV100 (index F)	A35025822
Overhaul kit EV100 (index G)	A35025823
Filter kit EV160 (index F)	A35030802
Service kit EV160 (index F)	A35030812
Overhaul kit EV160 (index F)	A35030822
Filter kit EV200 (index E-F)	A35035801
Service kit EV200 (index F)	A35035812
Overhaul kit EV200 (index F)	A35035822
Filter kit EV300 (index E-F)	A35040801
Service kit EV300 (index F)	A35040812
Overhaul kit EV300 (index F)	A35040822
Filter kit EV400 (index A&D)	A35045800
Service kit EV400 (index A&D)	A35045810
Overhaul kit EV400 (index D)	A35045821
Filter kit EV630 (index C-D)	A35050800
Service kit EV630 (index C-D)	A35050810
Overhaul kit EV630 (index C-D)	A35050820

# EV Single Stage Oil Sealed Pump Combinations

Our comprehensive range of EV pumps and mechanical boosters, complete with connection kits to mount the mechanical booster allows the user to specify a complete system. The fitting of a mechanical booster to an EV rotary vane pump significantly increases pumping speed and vacuum performance of the system, as well as increasing the ultimate vacuum attainable by approximately one decade of pressure.

Specifying a combination is simply a process of selecting the EV pump, selecting the required mechanical booster (from catalogue) and the appropriate connection kit shown below. The connection kits are supplied as a kit of parts that allows them to be easily assembled, together with the EV pump and mechanical booster on site. Clear and concise instructions are included with the kits to make this a very simple process.

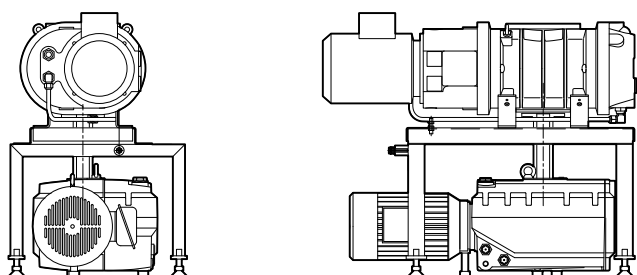

## Ordering Information Booster Connections

Primary pump	Booster								
	EH250	EH500	EH1200	607MV05	EH2600	615MV10 61BMV10	EH4200	615MV15 61BMV25	622MV25
EV100	NR7001000	NR7002000	NR7003000	NR7046000					
EV160		NR7006000	NR7007000	NR7047000		NR7050000			
EV200		NR7010000	NR7011000			NR7050000			
EV300		NR7014000	NR7015000		NR7016000	NR7050000	NR7017000	NR7050000	
EV400			NR7021000		NR7022000	NR7056000	NR7023000	NR7056000	
EV630			NR7028000		NR7029000	NR7056000	NR7030000	NR7056000	NR7064000

To ensure that both pumps and connecting kits are ordered:

Select the required EV pump – order as individual item

Select the required mechanical booster – order as individual item

Select the connection kit required to mount the booster on the EV pump from the table above – order as individual item

The three components will be supplied packed individually for assembly on receipt. The mounting kit contains simple instructions detailing the operations required to assemble the mounting kit and how to connect both the EV and mechanical booster together as a system.