

E2M0.7 Two Stage Rotary Vane Pump

The E2M0.7 is a small two stage oil sealed rotary vane pump that features a very low sound level of only 43 dB(A), compact dimensions, low energy consumption and low operating temperature. It will appeal to scientific instrument manufacturers and laboratory users for backing small turbomolecular or diffusion pumps as well as general laboratory applications.

Fitted in a cabinet, the pump will be virtually inaudible and the low operating temperature will minimize the heat load on the equipment. Vertical vacuum inlet with horizontal option.

Supplied with: Ultragrade 15 oil, NW O-ring and centering ring, 2 Allen keys and spare seals for oil drain and filler plugs.



Features & Benefits

- Very low sound level of only 43 dB(A).
- The pump is designed for reliable, long-term operation.
- Compact dimensions.
- Low energy consumption.
- Low operating temperature will minimize the heat load on the equipment.

Applications

- Analytical instruments
- Leak detectors, Helium
- Research and development
- Backing Turbomolecular pumps

Dimensions

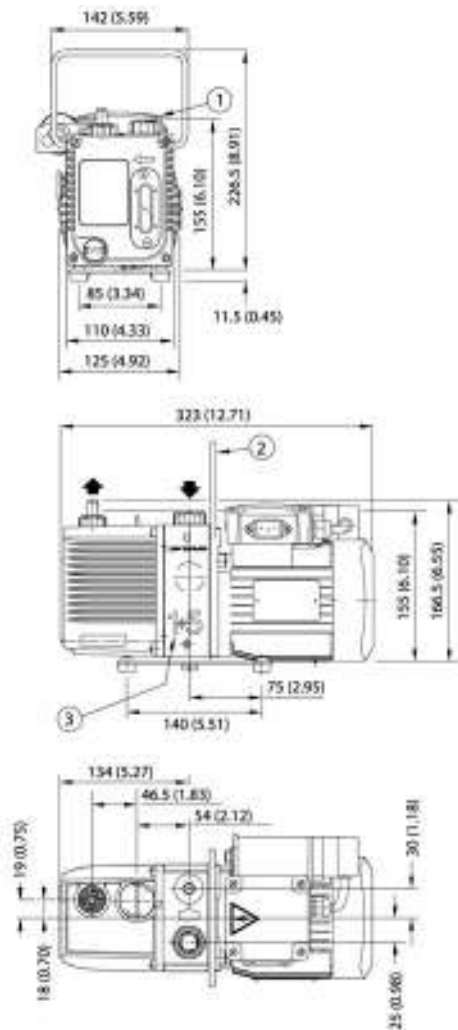

Performance Curves

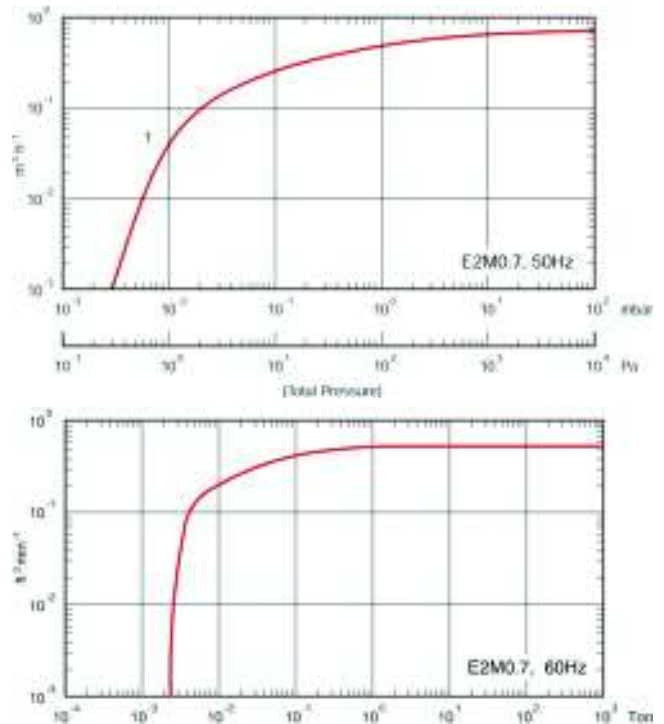

1 220-240 V motor 2 Handle (can be removed) 3 Alternative inlet position

Technical Data

Displacement (swept volume) 50 Hz	0.9 m ³ h ⁻¹ / 0.5 ft ³ min ⁻¹
Displacement (swept volume) 60 Hz	1.1 m ³ h ⁻¹ / 0.6 ft ³ min ⁻¹
Speed (Pneurop 6602) 50 Hz	0.75 m ³ h ⁻¹ / 0.4 ft ³ min ⁻¹
Speed (Pneurop 6602) 60Hz	0.95 m ³ h ⁻¹ / 0.5 ft ³ min ⁻¹
Ultimate vacuum (total pressure)	
without gas ballast	3.0 x 10 ⁻³ mbar / 2.3 x 10 ⁻³ Torr
with full gas ballast	2.0 x 10 ⁻¹ mbar / 1.5 x 10 ⁻¹ Torr
Inlet connection	NW10 flange
Outlet connection	Nozzle 11 mm external Ø removable from 3/8 inch BSP tapped hole
Maximum permitted pressure at outlet	0.5 bar gauge / 7 psig
Maximum inlet pressure for water vapour	15 mbar / 11 Torr
Maximum water vapour pumping rate	8 gh ⁻¹
Motor power	0.09 kW
Nominal rotational speed 50/60Hz	1400/1700 rpm
Power connector	IEC EN60320 C13
Operating temperature range	12 - 40 °C
Weight, without oil	10 kg / 22 lbs
Noise	43 dB(A) @ 50 Hz
Oil capacity - maximum	0.28 litre
Oil capacity - minimum	0.2 litre
Recommended oil (supplied)	Ultragrade 15

Ordering Information

Product Description	Order No.
E2M0.7 200-230V, 1-ph, 50/60Hz, IEC 60320 connectors	A37141919
E2M0.7 100-120V, 1-ph, 50/60Hz, IEC 60320 connectors	A37141902
Accessories & Spares	Order No.
Model EMF3 mist filter	A46220000
2m electrical supply cable for 1-ph pumps, UK, Three-pin plug	A50505000
2m electrical supply cable for 1-ph pumps, North European plug	A50506000
2m electrical supply cable for 1-ph pumps, North America/Japan plug	A50507000
2m electrical supply cable for 1-ph pumps, no plug	A50508000
Spares Kit C&O E2M0.7/1/1.5	A37101131
Spares Kit Blade E2M0.7/1.5	A37101132
NW10/10 Centring Nitrile S/S Pk1	C10511396
NW10 O Ring Viton Pk 5	H02124032
NW10 x 3/8 Bsp Adapter	A25908064

E2M1.5 Two Stage Rotary Vane Pump

The E2M1.5 is a two stage oil sealed rotary vane pump suitable for many bench type applications. The pump features an alternative inlet connection position at the side of the pump so that overall installation height can be reduced to a minimum when required.

The interstage version features an additional pumping port to provide a rough vacuum for auxiliary duties.

Supplied with: Ultrgrade 15 oil, NW O-ring, centering ring, 2 Allen keys and spare seals for oil drain and filler plugs.



Features & Benefits

- The pump is designed for reliable, long-term operation.
- Compact dimensions.
- Low energy consumption.
- The interstage version features an additional pumping port to provide a rough vacuum for auxiliary duties.
- The pump is a free-standing unit.

Applications

- Analytical instruments
- Laboratory bench top vacuum
- Leak detectors, Helium
- Research and development
- Backing turbomolecular pumps

Dimensions

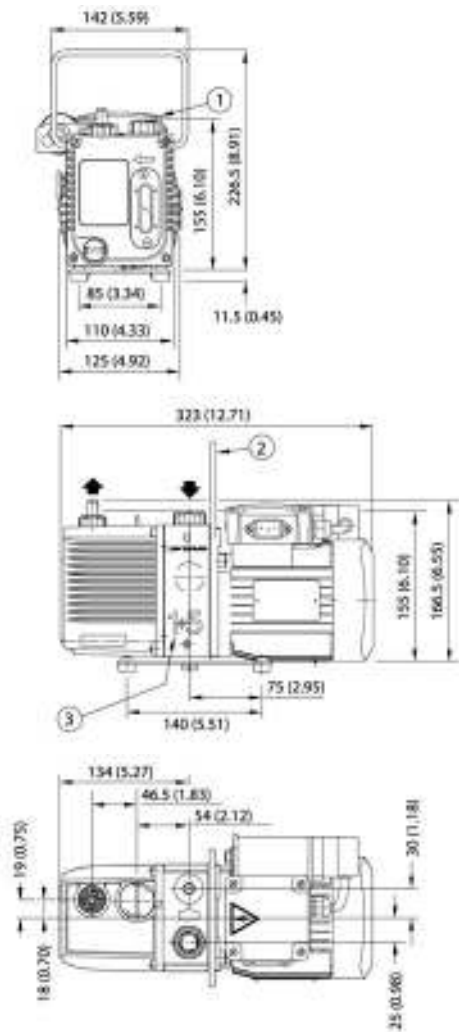

1 220-240 V motor 2 Handle (can be removed) 3 Alternative inlet position

Performance Curves

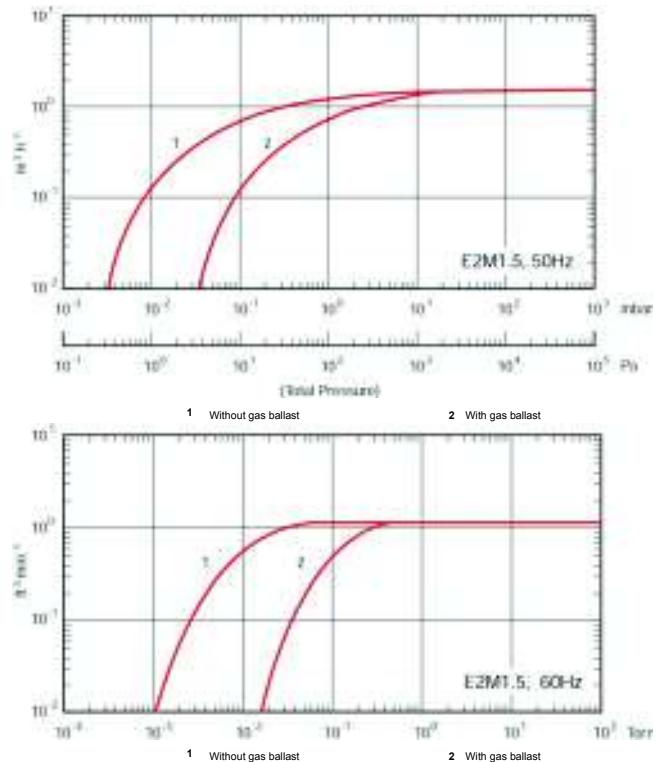

Technical Data

Displacement (swept volume) 50 Hz	1.8 m ³ h ⁻¹ / 1 ft ³ min ⁻¹
Displacement (swept volume) 60 Hz	2.2 m ³ h ⁻¹ / 1.3 ft ³ min ⁻¹
Speed (Pneurop 6602) 50 Hz	1.6 m ³ h ⁻¹ / 0.8 ft ³ min ⁻¹
Speed (Pneurop 6602) 60 Hz	2.0 m ³ h ⁻¹ / 1.2 ft ³ min ⁻¹
Ultimate vacuum (total pressure)	
without gas ballast	3 x 10 ⁻³ mbar / 2.3 x 10 ⁻³ Torr
with gas ballast	2.5 x 10 ⁻² mbar / 1.9 x 10 ⁻² Torr
Inlet connection	NW10 flange
Outlet connection	Nozzle 11 mm external diameter removable from hole tapped 3/8 inch BSP
Maximum permitted pressure at outlet	0.5 bar gauge / 7 psig
Maximum inlet pressure for water vapour	15 mbar / 11 Torr
Maximum water vapour pumping rate	16 gh ⁻¹
Motor power 50/60 Hz (IP54)	0.16 kW
Nominal rotation speed 50/60Hz	2800/3400 rpm
Power connector	IEC EN60320 C13
Operating temperature range	12 - 40 °C
Weight	10 kg / 22 lbs
Noise	54 dB (A) @ 50 Hz
Oil capacity - max	0.28 litre
min	0.2 litre
Recommended oil (supplied)	Ultragrade 15

Ordering Information

Product Description	Order No.
E2M1.5 200-230V, 1-ph, 50/60Hz, IEC 60320 connectors	A37132919
E2M1.5 100-120V, 1-ph, 50/60Hz, IEC 60320 connectors	A37132902
E2M1.5 interstage 200-230V, 1-ph, 50/60Hz, IEC 60320 connectors	A37104919
E2M1.5 interstage 100-120V, 1-ph, 50/60Hz, IEC 60320 connectors	A37104902
Accessories & Spares	Order No.
Model EMF3 mist filter	A46220000
2m electrical supply cable for 1-ph pumps, UK, Three-pin plug	A50505000
2m electrical supply cable for 1-ph pumps, North European plug	A50506000
2m electrical supply cable for 1-ph pumps, North America/Japan plug	A50507000
2m electrical supply cable for 1-ph pumps, no plug	A50508000
Spares Kit C&O E2M0.7/1.5	A37101131
Spares Kit Blade E2M0.7/1.5	A37101132
NW10/10 Centring Nitrile S/S Pk1	C10511396
NW10 O Ring Viton Pk 5	H02124032
NW10 x 3/8 Bsp Adapter	A25908064